

# Кровать Винні

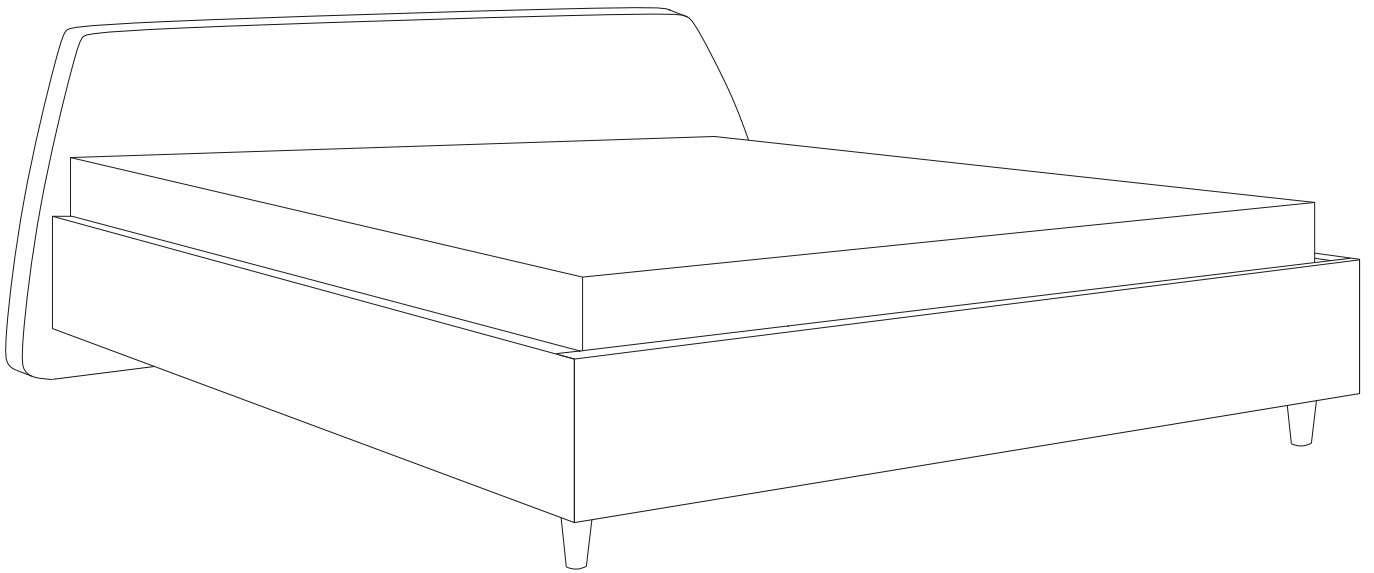

**Райтон**

природа сна

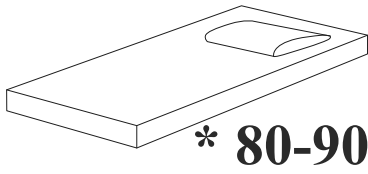

\* 80-90

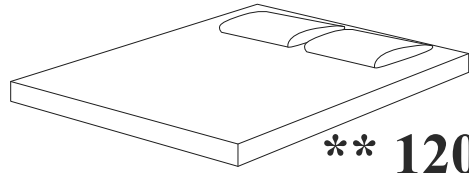

\*\* 120-180

**Φ1**



x16

**Φ2**



x28

**Φ3**



x6\*\*

**Φ4**



x6\*\*

**Φ5**



x6\*\*

**Φ6**



x8

**Φ7**

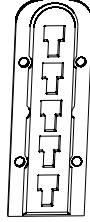

x2\*\*

**Φ8**



x14\*/28\*\*

**Φ9**

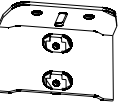

x2\*\*

**Φ10**

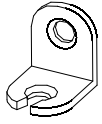

x6

**Φ11**



x8\*\*

**Φ12**

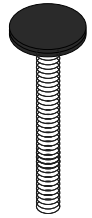

x3\*\*

**Φ13**

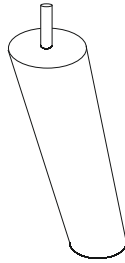

x2

**Φ14**



x2

**Φ15**



x2

**Φ16**

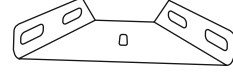

x2

**Φ17**



x2

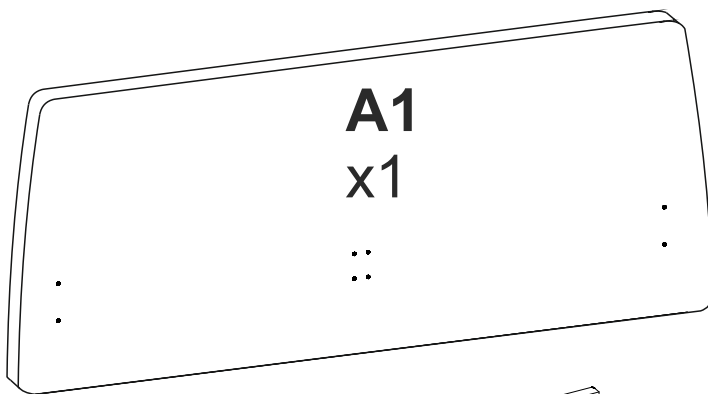

**A1**

x1

**A2**

x2

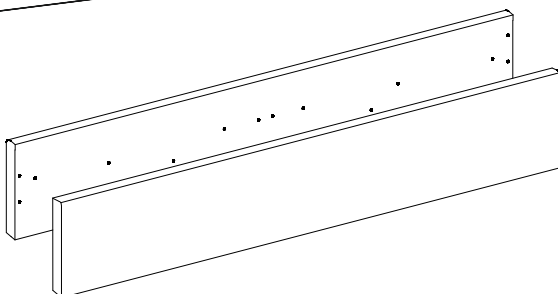

**A3**

x1

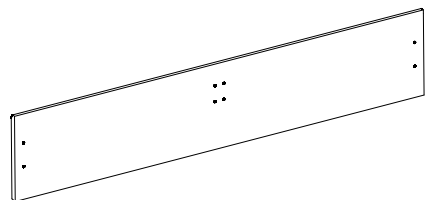

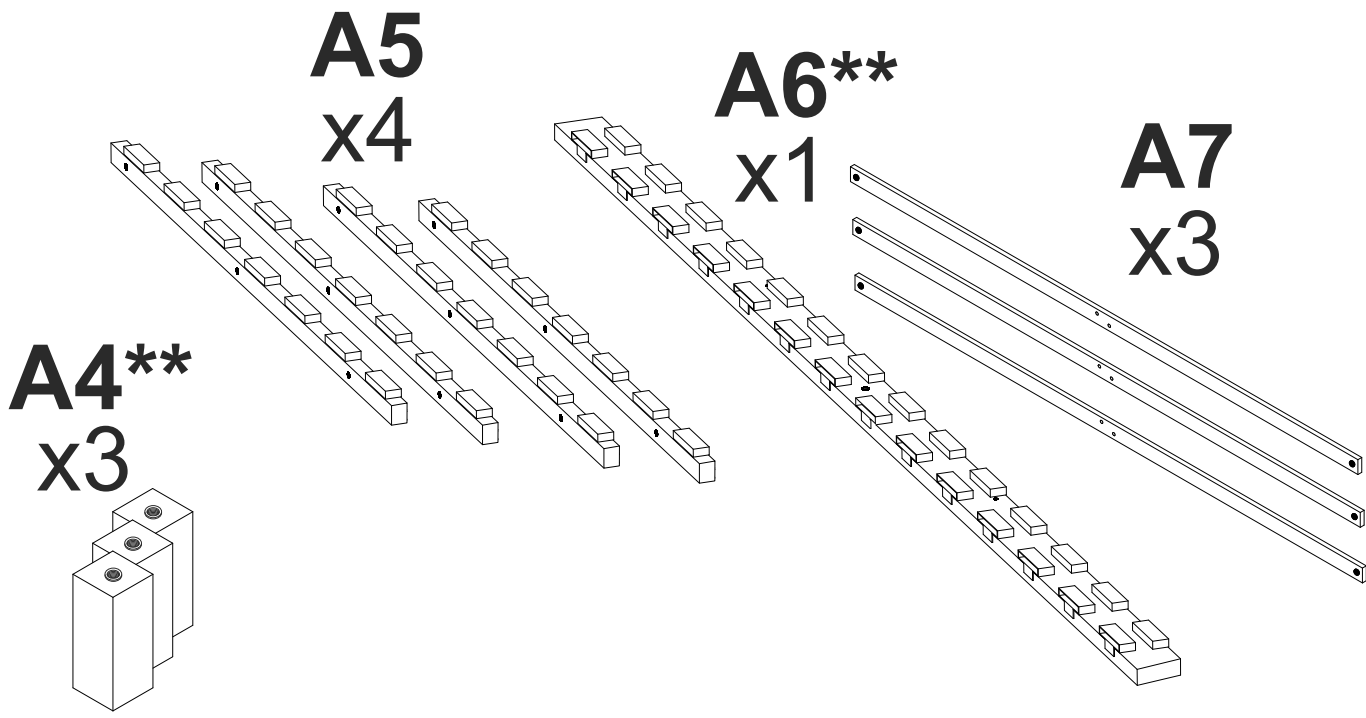

**1**

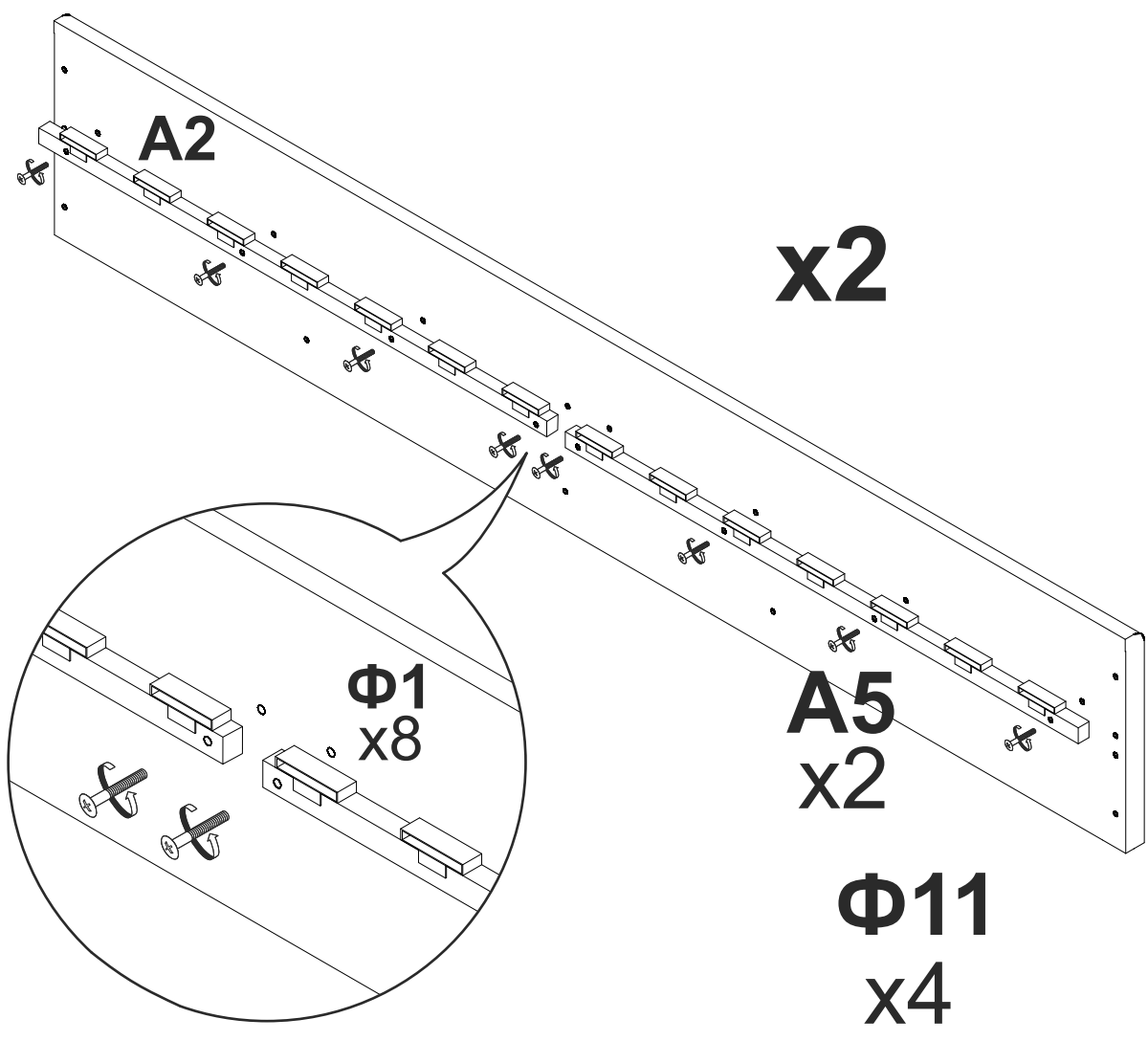

2

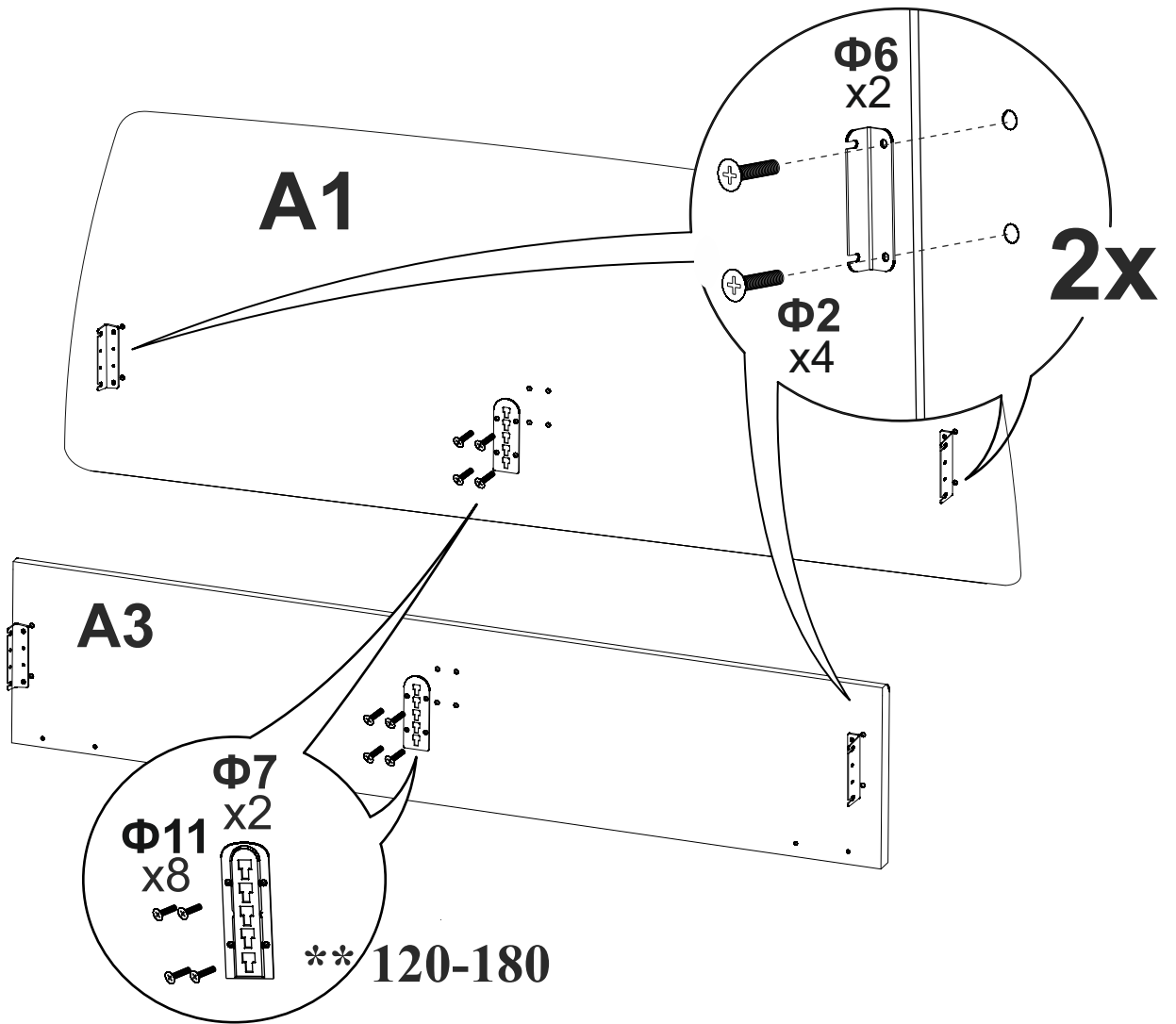

3

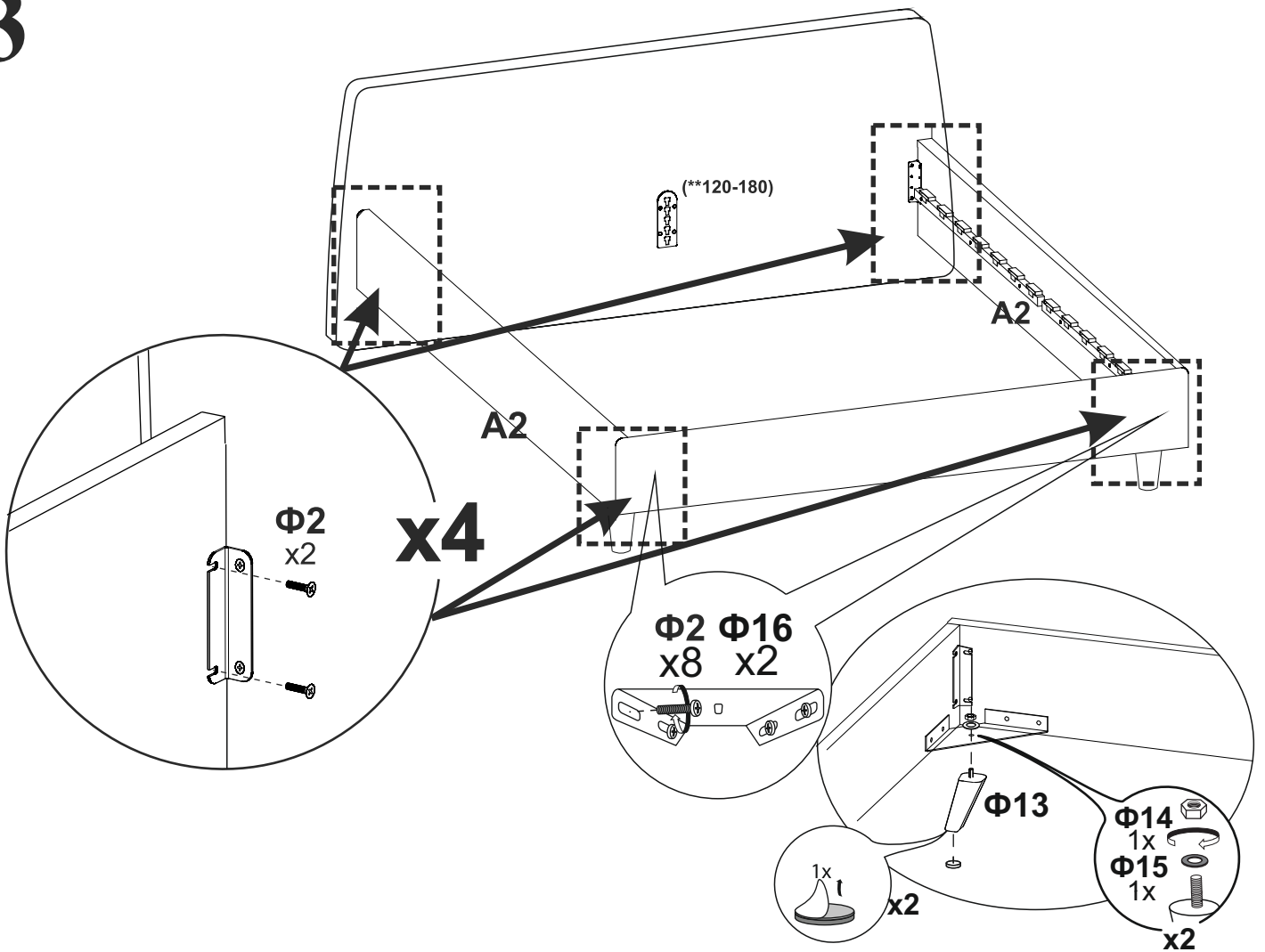

# 4 \*\* 120-180

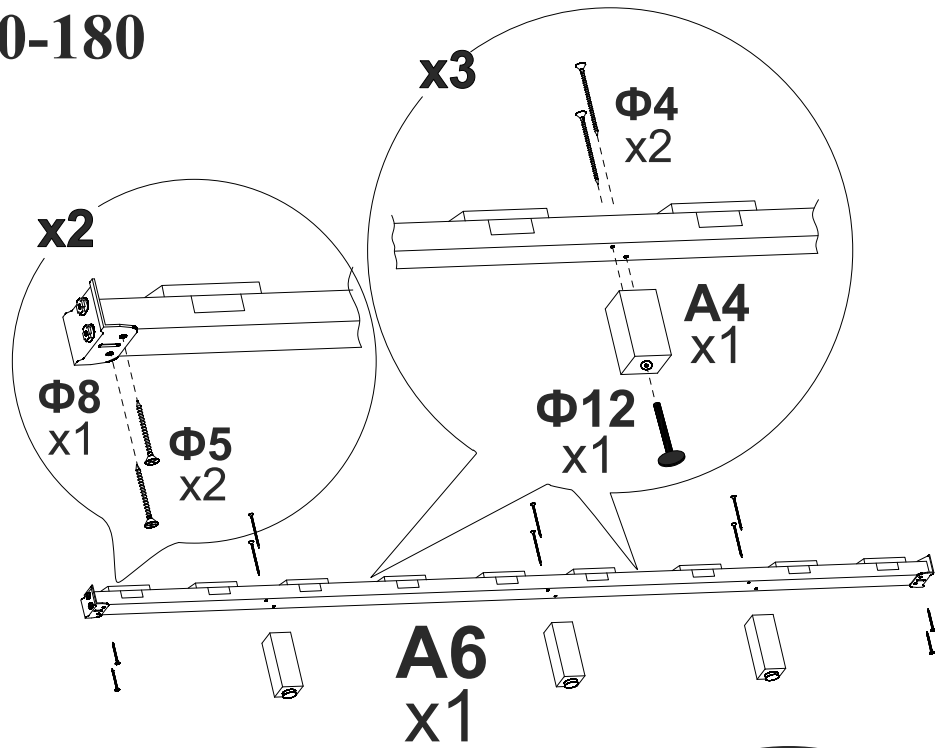

# 5 \*\* 120-180

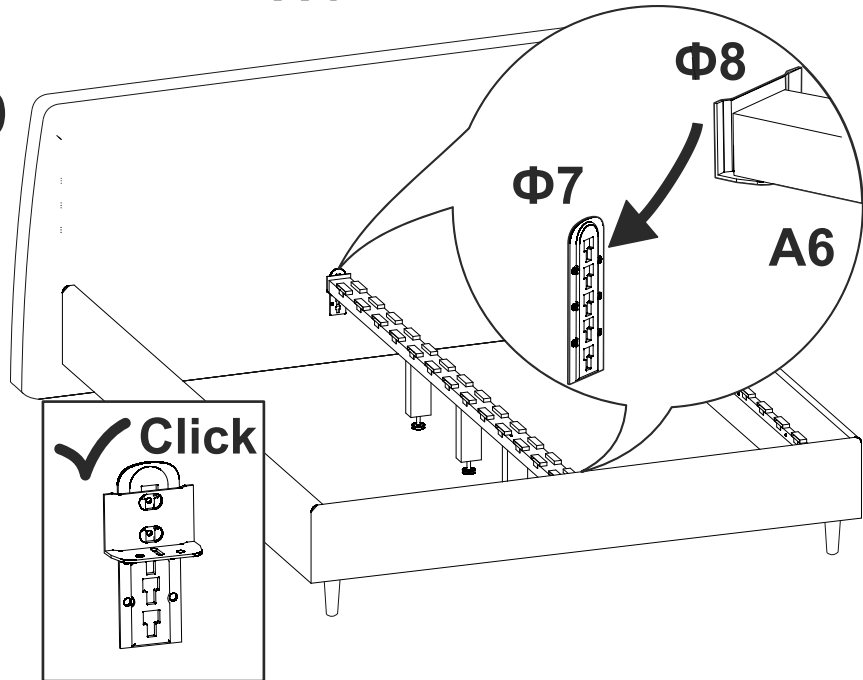

# 6 \*\* 120-180

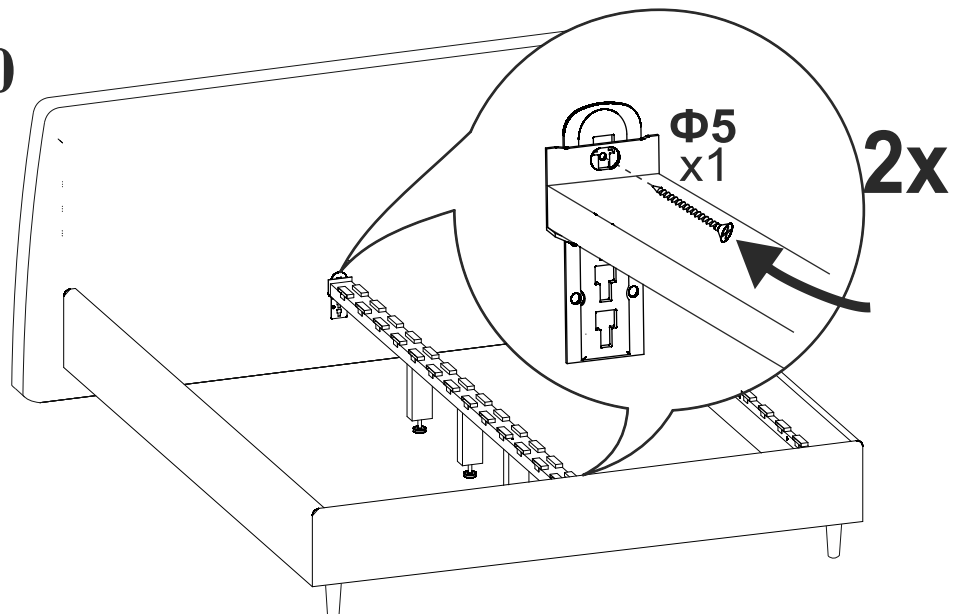

# 7\*\* 120-180

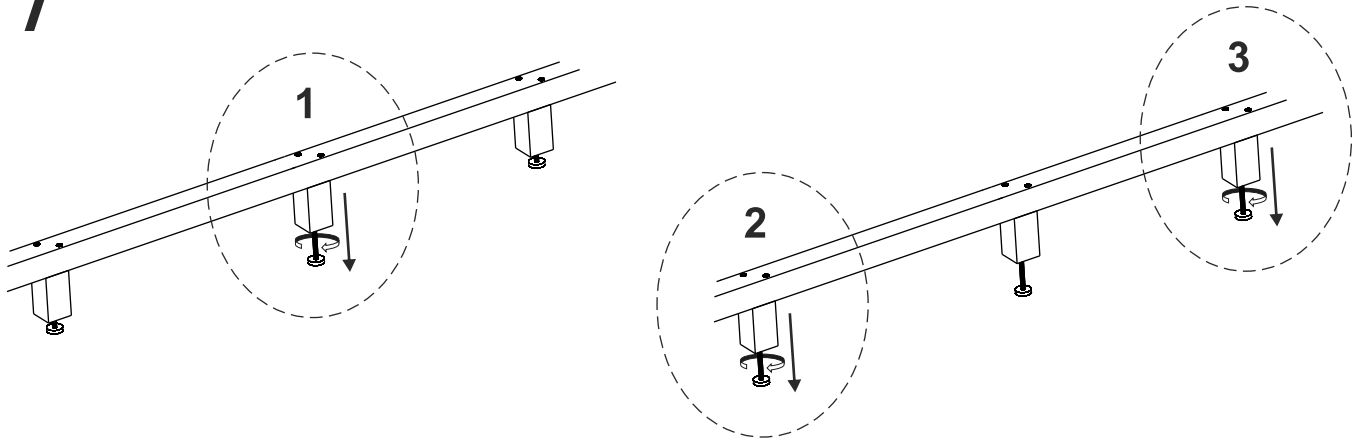

# 8\* 80-90

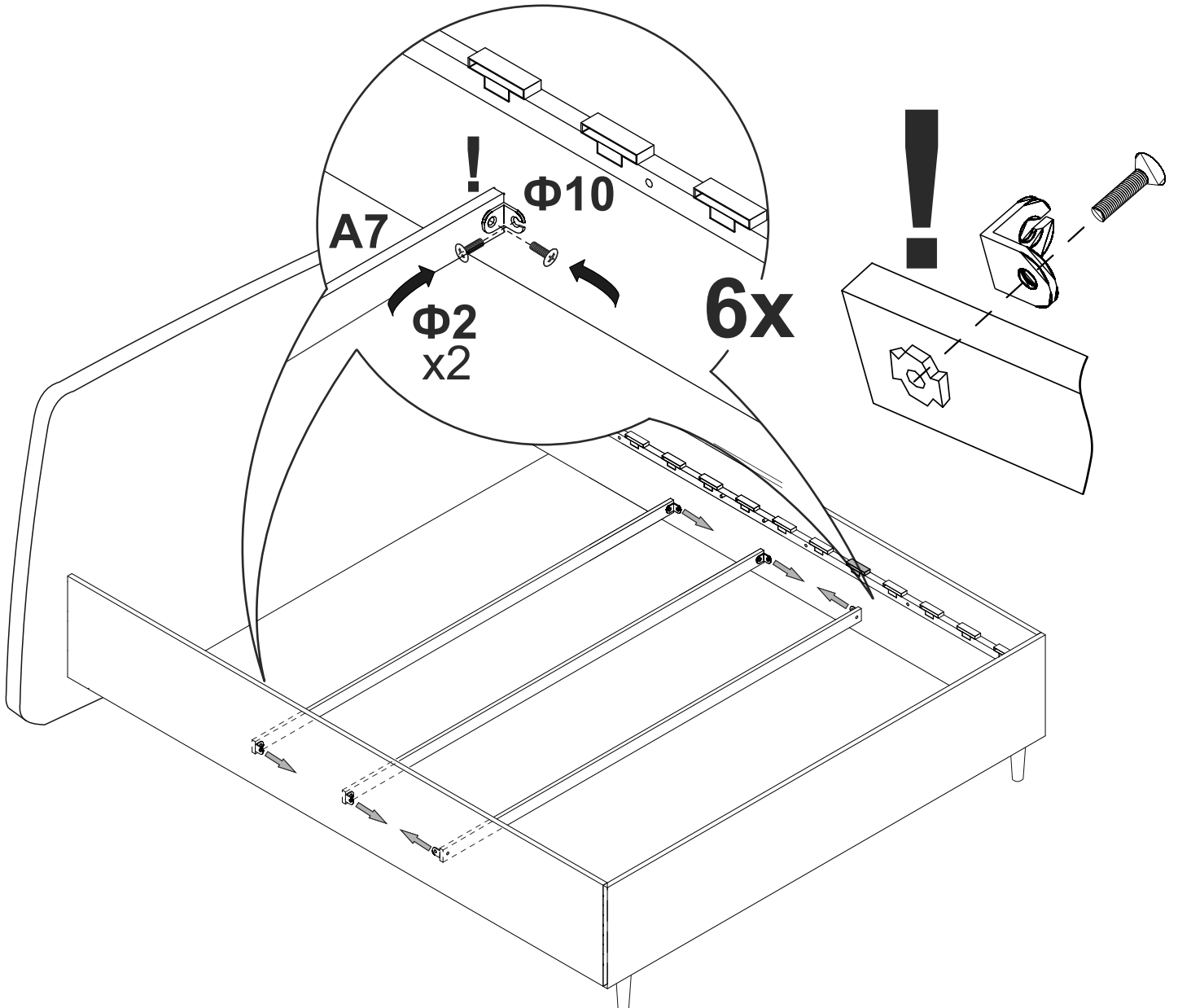

# 9 \*\* 120-180

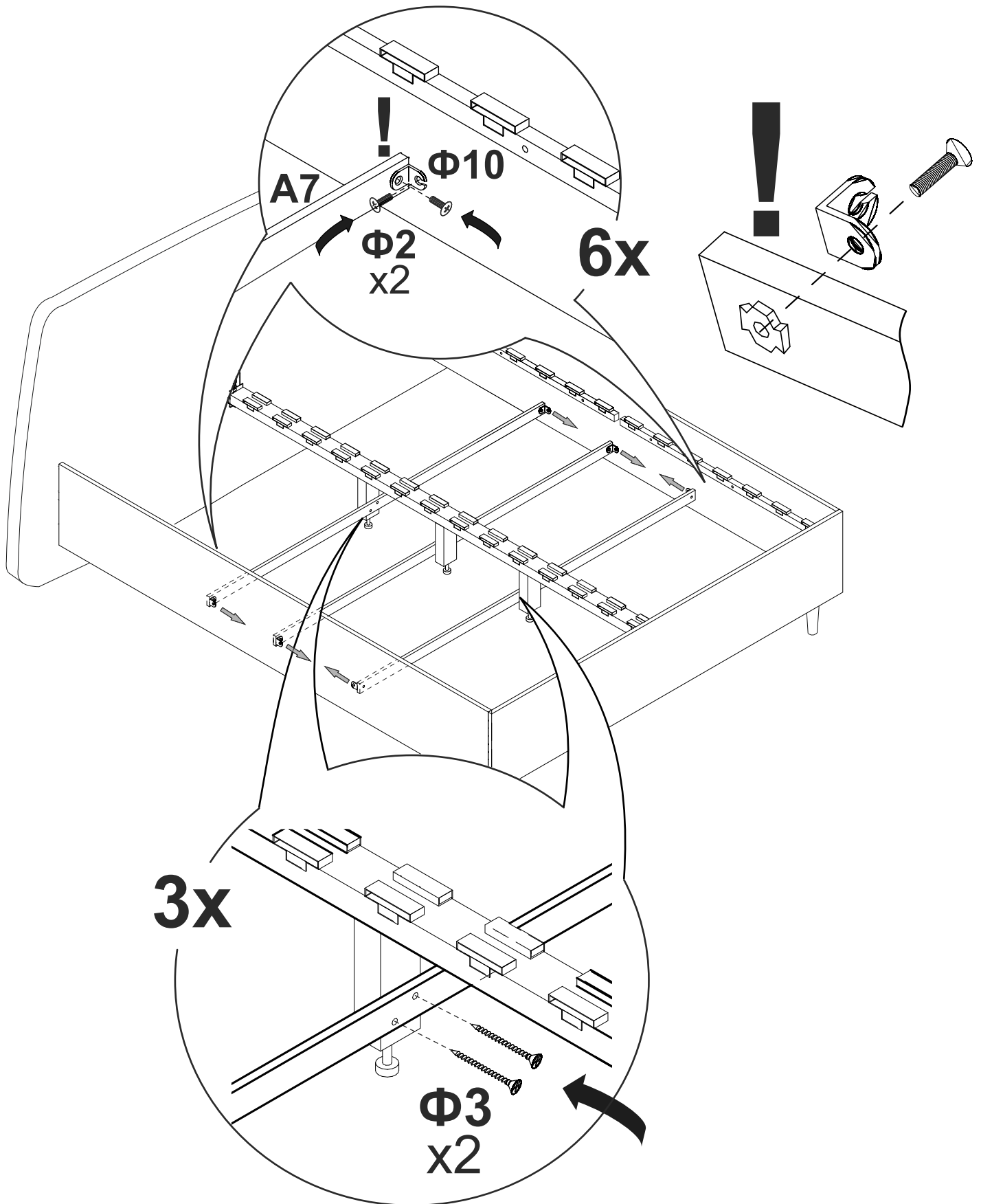

# 10

\* 80-90

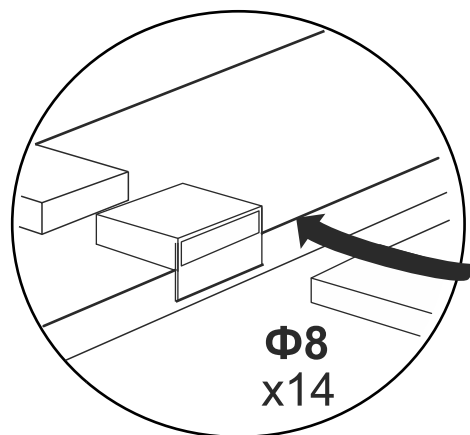
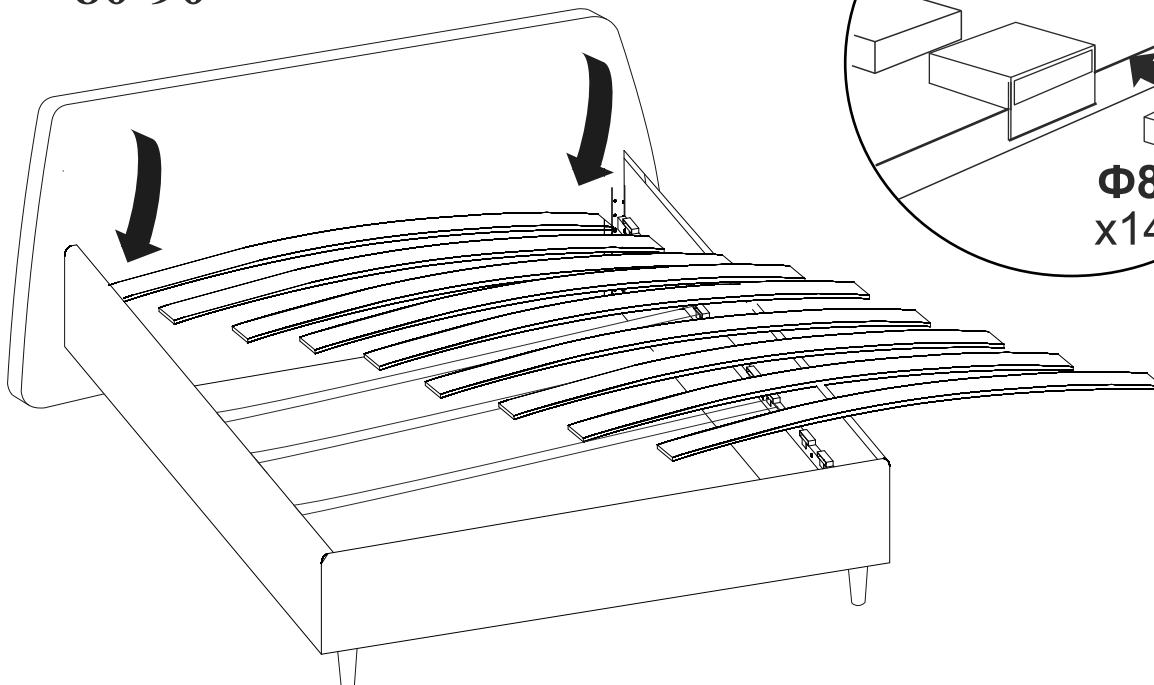

\*\* 120-180

